

Practice

Year end Math Assessment Grade 6

2016

NAME: ANSWERS

FORM: _____

INSTRUCTIONS

- Read through the test CAREFULLY before starting to answer any of the questions.
- You must hand in sections A and B before beginning section C!
- Don't waste time on a particular question, if you can't do it, move on and attempt it later. Work at a steady pace.
- SHOW YOUR WORK – this will ensure partial marks for questions where answers are incorrect.
- Be sure that ALL work is NEATLY presented.
- CHECK your calculations to avoid careless errors.

The test will be completed over two days

Day 1

Knowledge Questions

SECTION A

Short answer fill in the blanks. Each question is worth one mark. You do not have to show work.

NO CALCULATOR ALLOWED!

SECTION B

Short answer computation questions. See each question for marking scheme. Show your work! NO CALCULATOR ALLOWED!

SECTION C

Short answer computation questions. See each question for marking scheme. Show your work! CALCULATOR IS ALLOWED! You must hand in sections A and B before beginning section C!

Day 2

Application, Communication and Thinking

See each question for marking scheme. Show your work!

CALCULATOR IS ALLOWED!

Part A NO CALCULATOR!!!

For the following questions, write your answer in the blank spaces.

You do not have to show your work.

(Each question is worth one mark.)

1. 43 is a composite number. True or False. False
2. Write the fraction $26/4$ as a mixed number in simplest terms: $6\frac{1}{2}$
3. Angle RST and angle WXY are supplementary. If angle RST = 65° what size is angle WXY? 115°
4. Which sign: $<$, $>$ or $=$ makes this statement true: 0.850 0.085 $>$
5. Choose the correct answer: $5^3 = 10, 25, 15, 125$ 125
6. A triangle which has all three sides with the same length is called EQUILATERAL
7. Write in exponential form: $6 \times 6 \times 6 \times 6 \times 6$ 6^5
8. Which one of these numbers has both 8 and 6 as factors?
42 16 24 18 32 24
9. Is this statement true or false? $4539.4 = 4 + 3000 + 0.04 + 60$ FALSE
10. How many vertices are there on a rectangular prism? 8
11. If one period represents $1/3$ of a hockey game. How many hockey games have you played if you play 11 periods of hockey? $3\frac{2}{3}$
12. Round 36.257 to the nearest tenth 36.3
13. True or False: 4 is a multiple of 52?. FALSE
14. If you divide the circumference of a circle by its diameter, what result do you get?
 π
15. What name is given to an angle that is greater than 180° and less than 360° ?
REFLEX.

Part B NO CALCULATOR ALLOWED!!!

For the following questions show all your work in the space provided.

1. Write in columns below and add or subtract. (2 marks each)

(a) $23.116 + 54 + 14.23$

$$\begin{array}{r} 23.116 \\ 54.000 \\ 14.230 \\ \hline 91.346 \end{array}$$

(b) $3\,563.1 - 484.8$

$$\begin{array}{r} 3563.1 \\ - 484.8 \\ \hline 3078.3 \end{array}$$

2. Multiply or Divide. (2 marks each)

(a) 475.22

$$\begin{array}{r} 475.22 \\ \times 16.3 \\ \hline 142566 \\ 2851320 \\ 4752200 \\ \hline 7746086 \end{array}$$

(b) $4.1 \overline{) 68.32}$

$$\begin{array}{r} 16.663 \\ 41 \overline{) 683.200} \\ \underline{41} \\ 273 \\ \underline{246} \\ 272 \\ \underline{246} \\ 260 \\ \underline{246} \\ 140 \\ \underline{123} \\ \underline{17} \end{array}$$

3. Complete the following chart: ($\frac{1}{2}$ mark each)

NUMBER	$\times 10$	$\div 0.01$	$\times 0.1$	$\div 100$
432.8	4328	43280	43.28	4.328
9	90	900	0.9	0.09

4. Solve:

(3 marks)

$$\begin{aligned} & 4\frac{3}{5} - \frac{1}{2} + \frac{3}{10} \\ &= 4\frac{6}{10} - \frac{5}{10} + \frac{3}{10} \\ &= 4\frac{1}{10} + \frac{3}{10} \\ &= 4\frac{4}{10} \\ &= 4\frac{2}{5} \end{aligned}$$

5. Arrange from least to greatest. Final answer must be original in form (3 marks)

$\frac{1}{3}$	$\frac{2}{5}$	$\frac{7}{15}$	$\frac{3}{10}$
$\frac{10}{30}$	$\frac{12}{30}$	$\frac{14}{30}$	$\frac{9}{30}$
(2)	(3)	(4)	(1)

$$\frac{3}{10}, \frac{1}{3}, \frac{2}{5}, \frac{7}{15}$$

6. Arrange from least to greatest. (3 marks)

$\frac{3}{0.53}$	$\frac{4}{1.035}$	$\frac{1}{.053}$	$\frac{2}{0.503}$
------------------	-------------------	------------------	-------------------

$$0.053, 0.503, 0.53, 1.035.$$

Part C CALCULATOR ALLOWED!!!

For the following questions show all your work and formulas in the space provided.

1. Calculate (i) the perimeter and (ii) the area of the following shape. Write your final answers in the box. (2 marks each)

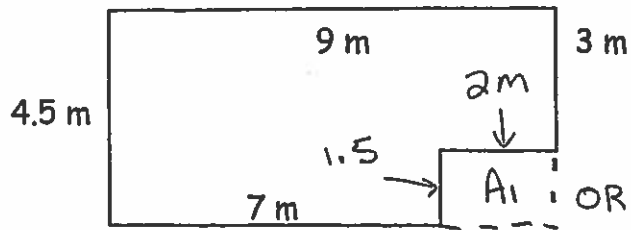

$$P = \text{SUM OF SIDES}$$

$$= 4.5 + 9 + 7 + 1.5 + 2 + 3$$

$$= 27m$$

$$P = 27m$$

$$A = 37.5m^2$$

OR $P = 2b + 2h$

$$= (2 \times 4.5) + (2 \times 9)$$

$$= 9 + 18$$

$$= 27m$$

$$A = A_T - A_1$$

$$A = (4.5 \times 9) - (2 \times 1.5)$$

$$= 40.5 - 3$$

$$= 37.5m^2$$

2. Calculate the area of the circle: (3 marks)

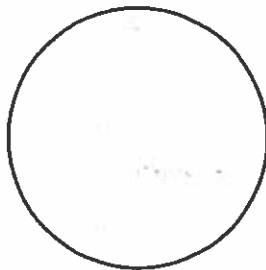

radius = 6 m

$$A = \pi \times r^2$$

$$= \pi \times 6^2$$

$$= 113.097$$

$$A = 113.10m^2$$

3. Calculate the volume of the cylinder. Write your final answer in the box. (3 marks)

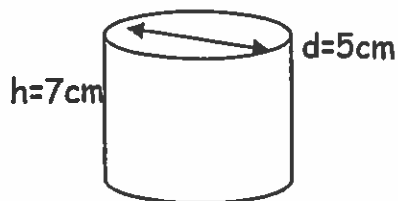

$$V = \text{area of face} \times h$$

$$= \pi \times r^2 \times h$$

$$= \pi \times \left(\frac{d}{2}\right)^2 \times h$$

$$= \pi \times 2.5^2 \times 7$$

$$= 137.4446$$

$$R = d \div 2$$

$$= 5 \div 2$$

$$= 2.5cm$$

$$V = 137.44cm^3$$

4. Without measuring, calculate the size of the missing angles. (1 mark each)

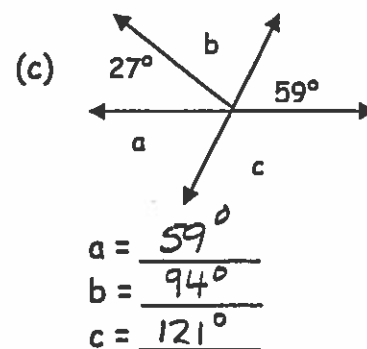
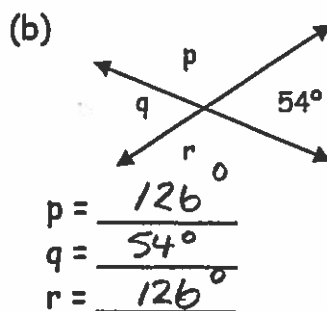
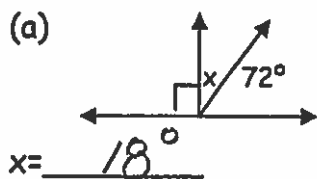

5. Express the following number as a "product of prime factors". (2 marks)

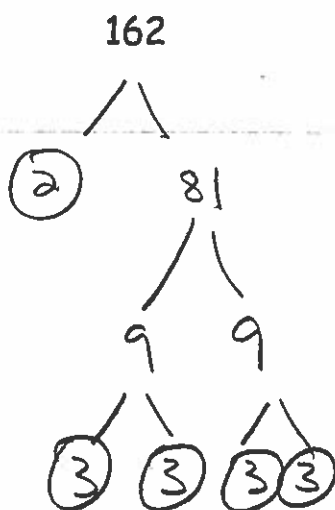

$2 \times 3 \times 3 \times 3 \times 3 = 162$ OR $2 \times 3^4 = 162$

6. Evaluate the following using order of operations (BEDMAS). Show each step in your solution: (2 marks each)

(a) $14 + 12 \div 2$

$= 14 + 6$

$= 20$

(b) $10 \times (2 + 3)^2 \div 5$

$= 10 \times 5^2 \div 5$

$= 10 \times 25 \div 5$

$= 10 \times 5$

$= 50$

(c) $7 \div \frac{1}{2} + 2 \times 1.5$

$= 7 \times \frac{2}{1} + 2 \times 1.5$

$= 14 + 3$

$= 17$

7. Place brackets in the following statement to make it true. (1 mark)

$$9 \times (8 - 2 \times 3) = 18$$

$$9 \times (8 - 6) = 18$$

$$9 \times 2 = 18$$

$$18 = 18$$

8. Solve the following operations with fractions. (1 mark each)

(a) $\frac{3}{2} + \frac{5}{6} - \frac{1}{4}$

$$= \frac{18}{12} + \frac{10}{12} - \frac{3}{12}$$

$$= \frac{25}{12}$$

(b) $\frac{1}{5} \times \frac{3}{4}$

$$= \frac{3}{20}$$

(c) $4\frac{1}{3} + \frac{5}{7} =$

$$4\frac{7}{21} + \frac{15}{21}$$

$$= 4\frac{22}{21}$$

$$= 5\frac{1}{21}$$

(e) $\frac{1}{5} \div \frac{3}{4} =$

$$= \frac{1}{5} \times \frac{4}{3}$$

$$= \frac{4}{15}$$

(d) $4\frac{2}{4} - 2\frac{2}{3} =$

$$= 4\frac{6}{12} - 2\frac{8}{12}$$

$$= 3\frac{18}{12} - 2\frac{8}{12}$$

$$= 1\frac{10}{12}$$

$$= 1\frac{5}{6}$$

$$4\frac{6}{12} - 2\frac{8}{12}$$

OR $= \frac{54}{12} - \frac{32}{12}$

$$= \frac{22}{12}$$

$$= \frac{11}{6}$$

Day 2

Application,
Communication and
Thinking

Application, Communication and Thinking (Calculator Allowed)

1. On average Martin drives 80 km / hour. How many km does Martin drive in one week if he drives for 12 hours per day? (3 marks)

$$\begin{aligned} \text{one weeks driving} &= 12 \times 7 \\ &= 84 \text{ hrs.} \end{aligned}$$

$$\begin{aligned} \therefore 80 \times 84 \\ &= 6720 \text{ KMS} \end{aligned}$$

$$\begin{aligned} 7 \text{ days} \times 12 \text{ hrs/day} \times 80 \text{ km/hr.} \\ &= 6720 \text{ KMS.} \end{aligned}$$

2. Olivia and Kate are each 156 cm tall, Andrew is 161 cm tall, David is 163 cm tall, and Jessica is 158 cm tall. How many girls' heights did you measure? (2 marks)

GIRLS

Olivia

Kate

Jessica

BOYS

Andrew

David

\therefore 3 girls heights were measured.

3. Identify the following solid shape and calculate the surface area of the shape. Write your final answer in the box.

Name of the solid shape: rectangular prism (1 mark)

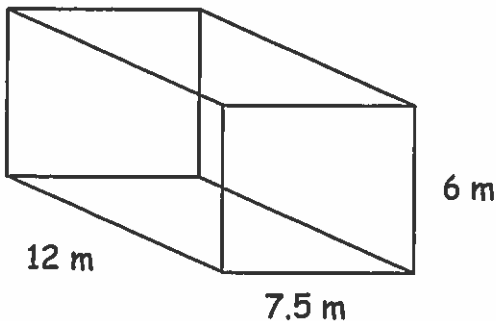

$$\boxed{SA = 414 \text{ m}^2} \text{ (3 marks)}$$

$$\begin{array}{ll} \text{TOP \& BOTTOM} & 12 \times 7.5 \times 2 = 180 \\ \text{SIDES} & 12 \times 6 \times 2 = 144 \\ \text{ENDS} & 7.5 \times 6 \times 2 = 90 \\ & \hline & 414 \text{ m}^2 \end{array}$$

OR

$$\begin{aligned} & P_F \times \text{depth} + A_F \times 2 \\ &= (6+6+7.5+7.5) \times 12 + 7.5 \times 6 \times 2 \\ &= 324 + 90 \\ &= 414 \text{ m}^2 \end{aligned}$$

4. Jennifer's mother made a deal with her about cleaning her room. She said she would give Jennifer \$1.00 for every day she cleaned her room, but Jennifer would have to pay her \$.50 for every day she did not clean her room. At the end of 25 days, Jennifer's has a total of \$19.00. How many days did Jennifer clean her room?

1	2	3	4	5	6	7	8	9	10	11
Y	Y	Y	Y	Y	Y	Y	Y	Y	Y	Y
12	13	14	15	16	17	18	19	20	21	
Y	Y	Y	Y	Y	Y	Y	Y	Y	Y	
22	23	24	25							
N	N	N	N							

∴ Jennifer cleaned her room for 21 days.

(*) 21 days cleaned room
 $\$21 - 4 \times .50 = \19

5. Daniel rides his bike for $1\frac{1}{4}$ hours each day on the weekend (Saturday and Sunday) How many hours will he ride over the course of 5 weekends? How many km will he ride over the course of these 5 weekends if he rides at a speed of 15 km / hour? (2 marks)

A $1\frac{1}{4}$ hrs/day Sat & Sun, 5 weekends, 15 km/hr

F hours ridden & distance

F X

C $1\frac{1}{4} \times 2 \times 5 = 12\frac{1}{2}$ hours.

$15 \times 12\frac{1}{2} = 187\frac{1}{2}$ Kms.

Daniel will ride $12\frac{1}{2}$ hours and travel $187\frac{1}{2}$ Kms over the 5 weekends.

6. (a) The track coach would like to paint the surface of this track purple (for HSC). To figure out how much paint he will need, calculate the area of the running surface (only) of this track. (3 marks)

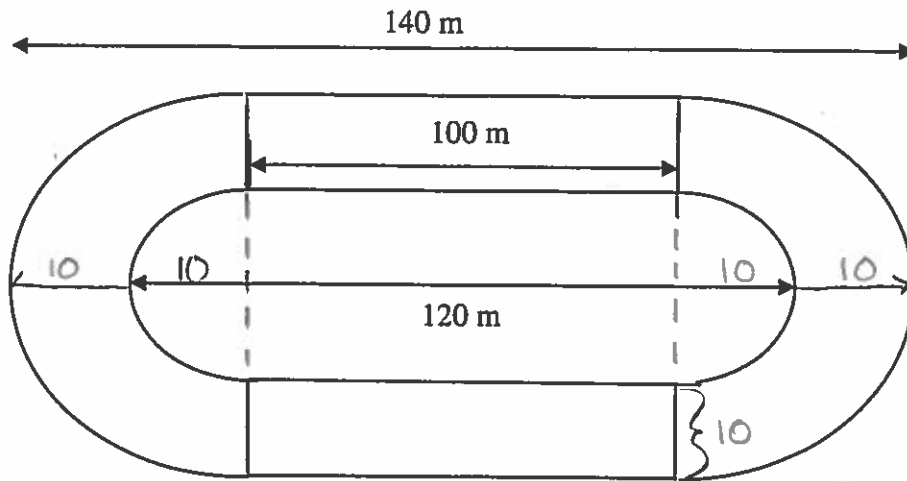

$A = \text{curves} + \text{straights}$

$$= \left(\frac{\pi r^2}{2} - \frac{\pi r^2}{2} \right) \times 2 + b \times h \times 2$$

$$= \left(\frac{\pi \times 20^2}{2} - \frac{\pi \times 10^2}{2} \right) \times 2 + 100 \times 10 \times 2$$

$$= (628.3185 - 157.0796) \times 2 + 2000$$

$$= 942.4778 + 2000$$

$$= 2942.4778$$

$$= 2942.48 \text{ m}^2$$

\therefore the coach will need to paint 2942.48 m^2

7. Charlie says that you can use two methods when finding the surface area of prisms and pyramids. Sam says that you can use two methods for finding the surface area of prisms but only use one method when finding the surface area of pyramids. Who is correct and why?

Sam is correct. When finding the surface area of pyramids you cannot use the method $P_F \times \text{depth} + A_F \times 2$ because pyramids do not have a face that is constant through the shape while prisms do have a face that is constant through the shape.